



Compact Cooked-Rice Mixer

"SHARIKKA" MCR-SSC



将混合米饭和醋的程序自动化，达致完美的效果。

Compact Cooked-Rice Mixer "SHARIKKA" MCR-SSC

特点

- 小巧的设计节省了安装所需的空間，适用于细小的厨房。
- 轻触式的操作屏幕让操作变成简易。
- 不施加压力的搅拌米饭方式，让米饭不轻易被损害，可以制作出最优质的寿司饭，就像由充满经验的寿司师傅制作一样。
- 提供三种不同已设定的混合程序，根据不同类型和份量的米饭作调节。
- 利用内置的鼓风机，米饭可以在混合的过程中冷却至一个适当的温度。
- 可用于各种应用；例如把米饭混合寿司醋、混合米饭跟各种类型的混合物、把米饭弄至一个更加松软的状态等。
- 利用盛饭鼓的简单轻触式操作，可以轻易的把米饭打松，达致最佳的搅拌效果。
- 需清洗的组件可以在没有工具的协助下拆卸及重组，让清洁的工作变得更加容易。
- 电线可以接驳至家用电源插座中。

规格

型号

Sharikka MCR-SSC

电源

AC120, 60Hz Single phase (machine without CE mark)

AC100 - 240V, 50 - 60 Hz Single phase
(machine with CE mark)

消耗电力

95W

外观尺寸

阔 496 mm

深 589 mm

高 835 mm

* 以上尺寸没有把盛饭鼓和其他设置计算在内。

米饭容量

最多放置熟饭 6 kg

机动性

完全自动化

(把米饭放置于盛饭鼓的程序需为人手操作。)

外形图

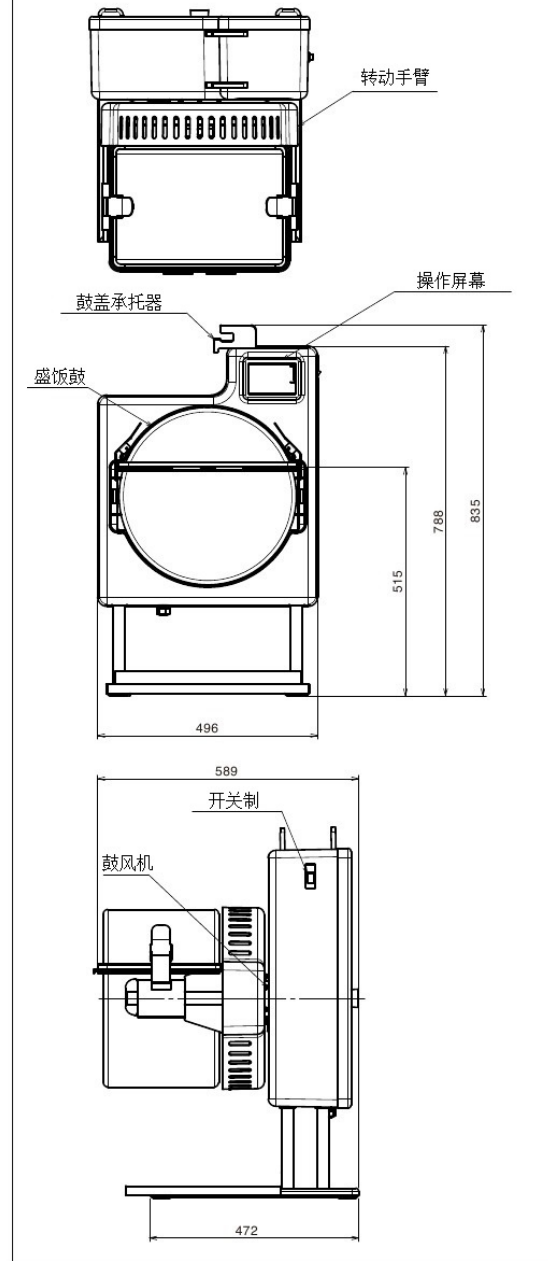

机器的使用方法以『使用说明书』为准。
上述机器的生产能力为标准设计性能，实际操作时会有差异。
机器的外形以及性能等有可能在不预先通知的情况下进行改良。



Suzumo Machinery Co., Ltd.

Overseas Business Division

2-23-2, Toyotamakita, Nerima-ku,
Tokyo 176-0012, Japan

Tel. +81 3-3993-1407 Fax. +81 3-3993-1756

e-mail overseas@suzumo.co.jp

URL <http://www.suzumokikou.com>

< Contact in North America >

Suzumo International Corporation

379 Van Ness Ave., Suite 1406

Torrance, California 90501, U.S.A.

Tel. +1 310-328-0400

Fax. +1 310-328-2700

e-mail sic@suzumokikou.com

中國代理商
Agent of China

HOSHING 浩誠
HOSHING

香港及澳門代理商
Agent of HK & Macau

ANEL
APEX NOBLE EQUIPMENT LTD.
雅麗盈設備有限公司

香港荃灣柴灣角街95號華俊工業中心18樓05號室

Flat 5, 18/F, Wah Chun Industrial Centre,

95 Chai Wan Kok Street, Tsuen Wan, New Territories, Hong Kong

Mobile: 852-94505051, 853-62839652, 86-14715675669

Tel: 852-36901333, 36901338, Fax: 852-36901339

Website: www.anel.com.hk

地址: 上海南京西路1717號會德豐國際廣場25樓1單元

電話: (021) 3251-9706 傳真: (021) 6282-0178

聯絡人: 吳先生 (86) 138-0889-0514

楊先生 (86) 150-1763-3656

Compact Cooked-Rice Mixer "SHARIKKA" MCR-SSC

Features

- The compact design saves installation space, ideal for a small kitchen.
- Touch-panel screens enable easy operation.
- Blending method without pressure on rice enables to produce highest quality "shari" (sushi rice) just like experienced sushi chef's make.
- Three different pre-set blending programs are selectable, depending on the type and amount of rice.
- Rice can be cooled down to the appropriate temperature by a built-in blower during the blending process.
- Available for various applications; "Shari" blended with sushi vinegar, mixed rice with assorted mixtures, loosened rice in fluffier condition and etc.
- The "shari" or processed rice is easily discharged from the drum by a simple touch operation.
- Easy cleaning is possible as washable parts can be dismantled and reassembled without tools.
- Connectable to household electric outlets.

Specifications

Model

Sharikka MCR-SSC

Power

AC120, 60 Hz Single phase (machine without CE mark)

AC100-240V, 50-60 Hz Single phase
(machine with CE mark)

Power consumption

95W

External dimensions

Width 496 mm (19.5 in)

Depth 589 mm (23.2 in)

Height 835 mm (32.9 in)

* The dimensions do not contain bumps and bosses.

Rice Amount Capacity

Maximum 6kg (13.2 lb) of cooked rice

Mechanism

Fully automatic

(Placing the rice into the drum is done manually.)

Dimensions

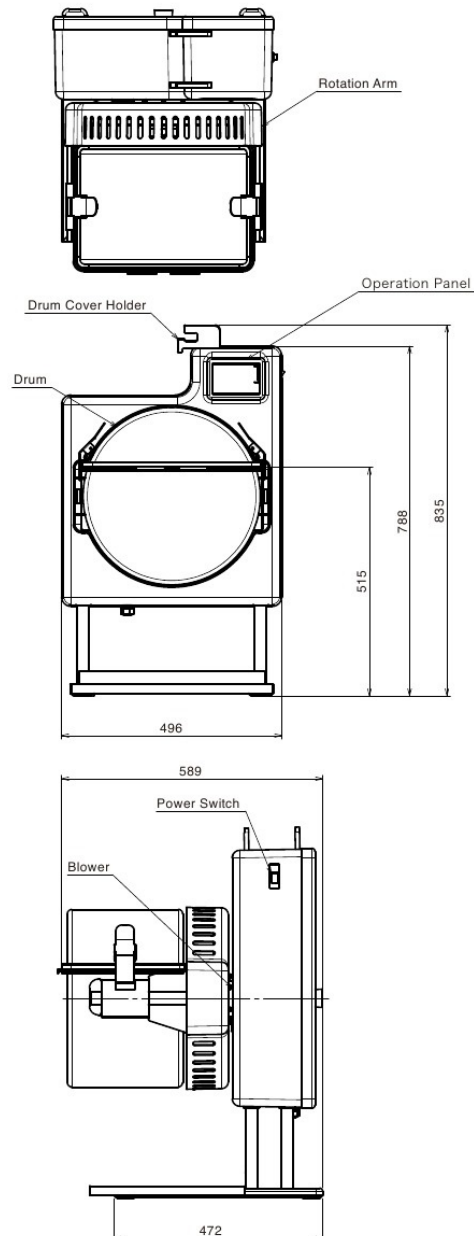

* Designs and specifications subject to change without notice.

* Please follow the directions in the operations manual when handling the machine.

* While capacity expresses the machine's performance capabilities, it is predicated upon the machine being operated correctly.



Suzumo Machinery Co., Ltd.

Overseas Business Division

2-23-2, Toyotamakita, Nerima-ku,
Tokyo 176-0012, Japan

Tel. +81 3-3993-1407 Fax. +81 3-3993-1756

e-mail overseas@suzumo.co.jp

URL <http://www.suzumokikou.com>

< Contact in North America >

Suzumo International Corporation

379 Van Ness Ave., Suite 1406

Torrance, California 90501, U.S.A.

Tel. +1 310-328-0400

Fax. +1 310-328-2700

e-mail sic@suzumokikou.com

中國代理商
Agent of China

HOSHING
浩誠

香港及澳門代理商
Agent of HK & Macau

ANEL

APEX NOBLE EQUIPMENT LTD.

雅麗盈設備有限公司

香港荃灣柴灣角街95號華俊工業中心18樓05號室

Flat 5, 18/F, Wah Chun Industrial Centre,

95 Chai Wan Kok Street, Tsuen Wan, New Territories, Hong Kong

Mobile: 852-94505051, 853-62839652, 86-14715675669

Tel: 852-36901333, 36901338, Fax: 852-36901339

Website: www.anel.com.hk

地址: 上海南京西路1717號會德豐國際廣場25樓1單元

電話: (021) 3251-9706 傳真: (021) 6282-0178

聯絡人: 吳先生 (86) 138-0889-0514

楊先生 (86) 150-1763-3656