

独特的装置可以制作出柔软的饭卷

可以制作连续或是单件的海苔卷

可调节大小和形状(圆形或是四方形)

有用于调节切割长度的转刀



CONTINUOUS Roll Sushi Machine

SVR-SAE-W

每小时可连续生产4,000卷，就像手制一样!!



Small 小卷



Medium 中卷



Large 大卷



Rice outside 饭卷



Single roll 单卷



米饭不断输出，可按照适当长度需求切割。



从一边卷起，再到另一边。

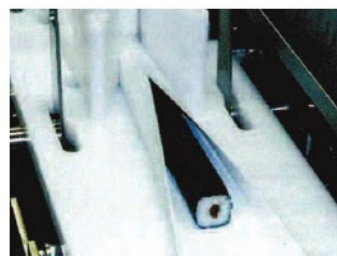

饭卷会自然地形成。



切割的长度可以调节。转刀需要用酒精保持清洁。

外形图

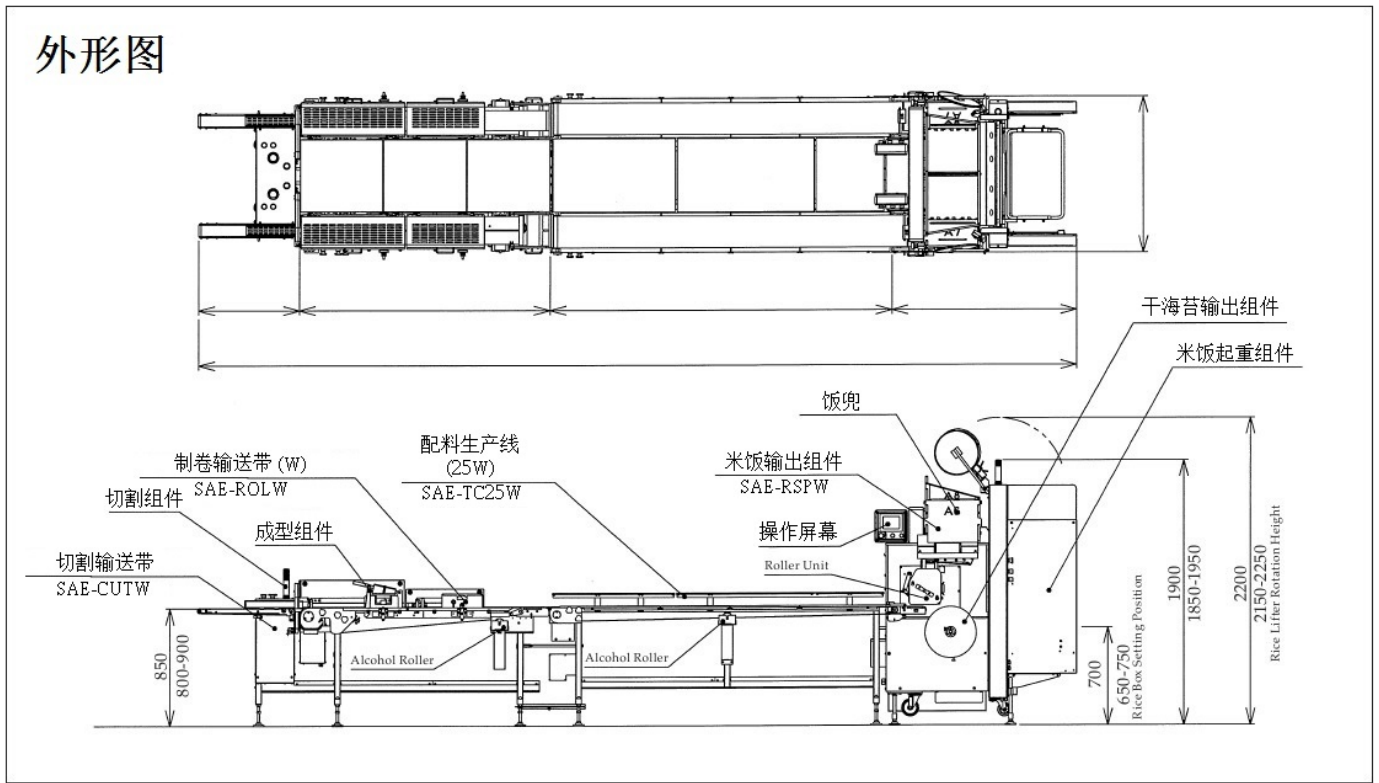

规格

电源

3-phase, 200V 50/60Hz

消耗电力

1.7kW (不包括非必须配件)

机械尺寸

6,360阔 X 1,115深 X 1,900长mm

配料输送带长度可供选择 (2 / 2.5 / 3m)

生产量

每小时4,000卷(以双生产线计算, 每卷长度180mm)

- 可调节生产速度
- 可选择生产单卷

卷物大小

小型 / 80 X 180mm (饭重大约80g)

中型 / 120 X 180mm (饭重大约140g)

大型 / 155 X 180mm (饭重大约235g)

起重机容量

不多于20kg

饭兜容量

15kg

可放置饭重

不多于860kg

特点

- 可以连续地输出柔软的米饭。
- 可以选择生产连续性的饭卷或是单卷亦可。
- 独立的配料生产线。
- 输送带的长度可以调节。(2 / 2.5 / 3m)
- 独特的形成机制, 先由一侧卷起, 再卷起另一侧。
- 饭卷的大小以及形状可以调节。
- 转刀可以于不同长度准确而利落地把饭卷切开。
- 为了操作者的安全, 内置了联锁系统。
- 每一条生产线也有其独立的轻触式操作屏幕。
- 最大的生产量是每小时4,000卷。(以两条生产线计算)
- 以安全和利落作为设计宗旨。

*机器的使用方法以「使用说明书」为基准。

*上述机器的生产能力为标准性能指数, 实际使用会有所差异。

*机器的外形及设计有可能不予通告加以改良。



Suzumo Machinery Co., Ltd.

Overseas Business Division

2-23-2, Toyotamakita, Nerima-ku,
Tokyo 176-0012, Japan

Tel. +81 3-3993-1407 Fax. +81 3-3993-1756

e-mail overseas@suzumo.co.jp

URL http://www.suzumokikou.com

< Contact in North America >

Suzumo International Corporation

1815 W. 205th Street, Suite 101
Torrance, CA 90501, U.S.A.

Tel. +1 310-328-0400

Fax. +1 310-328-2700

e-mail sic@suzumokikou.com

中國代理商
Agent of China

HOSHING
浩 誠

地址: 上海南京西路1717號會德豐國際廣場25樓1單元

電話: (021) 3251-9706 傳真: (021) 6282-0178

聯絡人: 吳先生 (86) 138-0889-0514

楊先生 (86) 150-1763-3656

香港及澳門代理商
Agent of HK & Macau

ANEL

APEX NOBLE EQUIPMENT LTD.

雅麗盈設備有限公司

香港荃灣柴灣角街95號華俊工業中心18樓05號室

Flat 5, 18/F, Wah Chun Industrial Centre,

95 Chai Wan Kok Street, Tsuen Wan, New Territories, Hong Kong

Mobile: 852-94505051, 853-62839652, 86-14715675669

Tel: 852-36901333, 36901338, Fax: 852-36901339

Website: www.anel.com.hk

Dimensions

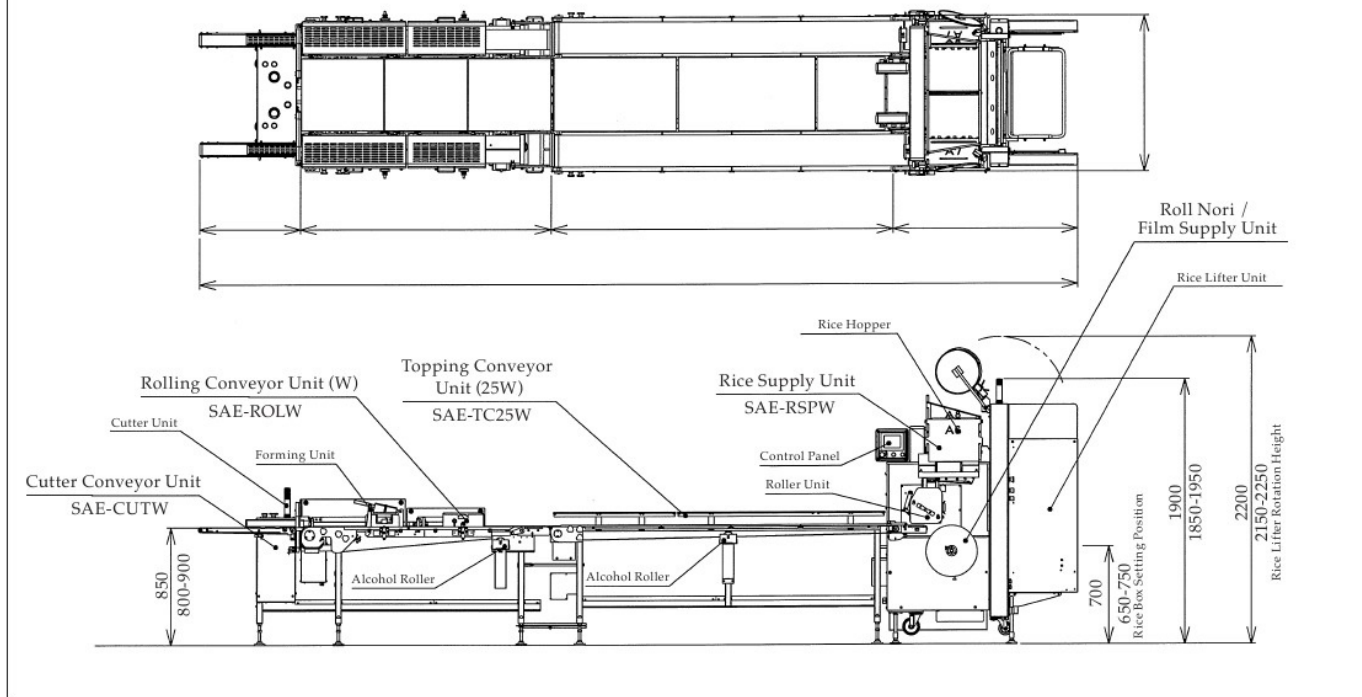

Specifications

Power

3-phase, 200V 50/60Hz

Power consumption

1.7kW (excluding optional accessories)

Machine dimensions (in mm)

6360W x 1115D x 1900Hmm (Max. 2250Hm)

Topping Conveyor Unit selectable (2/2.5/3/3.5m)

Capacity

4000 rolls per hour (double lines, roll length at 180mm)

- Speed adjustable
- Single roll selectable

Roll Size (selectable)

Small / 80 x 180mm (rice weight approx. 80g)

Medium / 120 x 180mm (rice weight approx. 140g)

Large / 155 x 180mm (rice weight approx. 235g)

Lifter Capacity

Under 20kgs

Hopper Capacity

15kg

Weight

Under 860kg

Features

- Continuous output of soft, consistent rice sheet.
- Continuous rice sheet or single rice sheet selectable.
- Independent topping conveyor.
- Conveyor length is selectable (2/2.5/3/3.5m)
- Unique forming mechanism, by rolling up from one side, then the other side.
- Roll size and shape can be changed by exchanging forming units.
- Rotary cutter will cut rolls sharply by variable lengths.
- Equipped with an interlock system for operator's safety.
- Each line has its own touch panel controller.
- Maximum capacity 4000 rolls per hour (with 2 lines)
- Designed safe and clean.

* Designs and specifications subject to change without notice.

* Please follow the instruction in the operation manual when handling the machine.

* While capacity expresses the machine's performance capabilities, it is predicated upon the machine being operated correctly.



Suzumo Machinery Co., Ltd.

Overseas Business Division

2-23-2, Toyotamakita, Nerima-ku,
Tokyo 176-0012, Japan

Tel. +81 3-3993-1407 Fax. +81 3-3993-1756

e-mail overseas@suzumo.co.jp

URL <http://www.suzumokikou.com>

< Contact in North America >

Suzumo International Corporation

1815 W. 205th Street, Suite 101
Torrance, CA 90501, U.S.A.

Tel. +1 310-328-0400

Fax. +1 310-328-2700

e-mail sic@suzumokikou.com

中國代理商
Agent of China

HOSHING
浩誠

地址: 上海南京西路1717號會德豐國際廣場25樓1單元

電話: (021) 3251-9706 傳真: (021) 6282-0178

聯絡人: 吳先生 (86) 138-0889-0514

楊先生 (86) 150-1763-3656

香港及澳門代理商
Agent of HK & Macau

ANEL

APEX NOBLE EQUIPMENT LTD.

雅麗盈設備有限公司

香港荃灣柴灣角街95號華俊工業中心18樓05號室

Flat 5, 18/F, Wah Chun Industrial Centre,

95 Chai Wan Kok Street, Tsuen Wan, New Territories, Hong Kong

Mobile: 852-94505051, 853-62839652, 86-14715675669

Tel: 852-36901333, 36901338, Fax: 852-36901339

Website: www.anel.com.hk