

Simple Operation and Professional Cutting Quality.



Fuji Keizai (Labour shortage and Potential Demand & Consideration on Automated Robots) Results for 2022 Sales Quantity and Value for Sushi Making Robot

More Capacity & More Safety.

- Easy setting & cleaning
- Easy cutting blade replacement
- Safety sensor for Front Cover
- Maximum 60mm diameter roll cut



Standard cutting unit are either 180mm-6pieces or 180mm-8pieces.

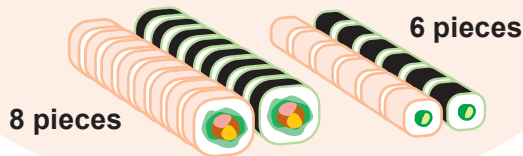

Automatic Roll Sushi Cutter SVC-ATC



SVC-ATC-ET
NRTL
IAPMO
EGS
C US



SVC-ATC-CE
CE
UK
CA

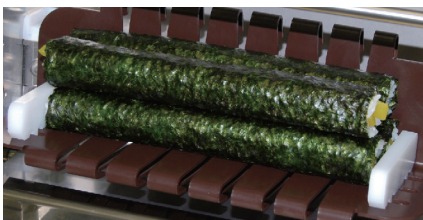

4 Small roll can be set on cutting table : 2,200 rolls / hr



2 Medium roll : 1,100 rolls / hr



1 Large roll (Rice outside roll) : 550 rolls / hr

Automatic Roll Sushi Cutter SVC-ATC

Unit: mm

■ Dimensions

(SVC-ATC-ET)

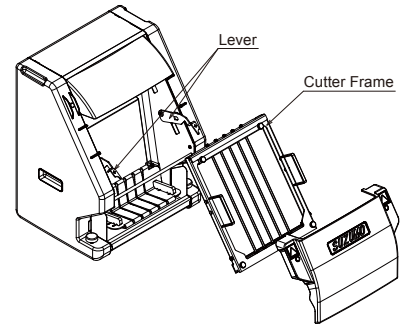
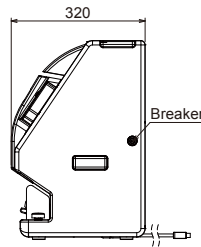
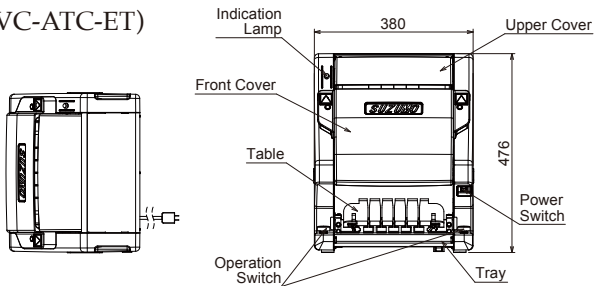

(SVC-ATC-CE)

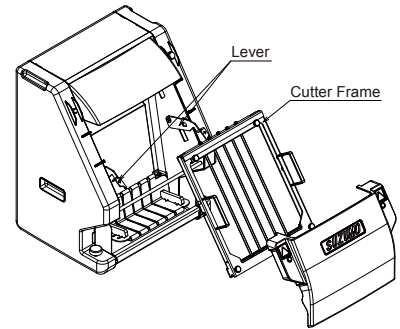
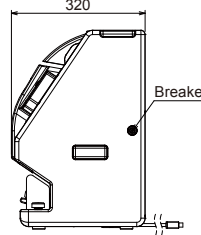
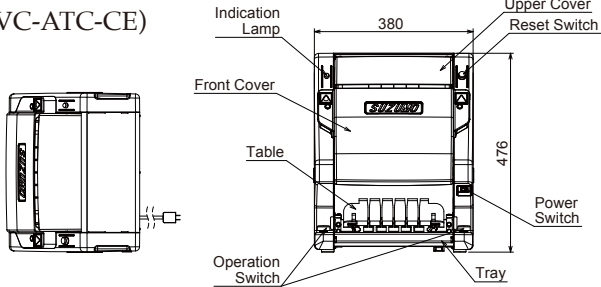

■ Specifications

Model

SVC-ATC-ET (Meets UL/NSF standards)
SVC-ATC-CE (Applied to CE & UKCA Regulation)

Input

AC100-240V, 50/60 Hz, Single phase

Power consumption

140W

Capacity

Small roll (25mm□): Approx 2,200 rolls/hr (4 rolls at one time)
Medium roll (35mm□): Approx 1,100 rolls/hr (2 rolls at one time)
Large roll (46-60mm□): Approx 550 rolls/hr (1 roll at one time)

Machine dimensions

380W×320D×476Hmm

Weight

Approx. 17Kg (include cutting table & flame)

Power connection cable

2m

Plug can be selectable among CE, BF, and UL type

■ Features

- Designed for safe operation and easy cleaning.
- Cutting unit can be designed as custom order basis. Standard cutting unit is either 180mm-6 pieces or 180mm-8 pieces.
- Wider cutting table can be set 3pieces of small rolls (*Hosomaki*) and cut at one time.
- Compact and lightweight design enables you to carry the machine wherever you wish.

* Designs and specifications are subject to change without notice.
* While capacity expresses the machine's performance capabilities, it is predicated upon the machine being operated correctly.

Suzumo Machinery Co., Ltd. Global Business Division

2-23-2, Toyotamakita, Nerima-ku, Tokyo 176-0012, Japan
Tel. +81 3-3993-1407 Fax. +81 3-3993-1756
e-mail overseas@suzumo.co.jp URL <https://www.suzumokikou.com>

< Contact in North America >

Suzumo International Corporation

Head Office : 1815 W. 205th Street, Suite 101 Torrance, CA 90501 U.S.A.
Tel. +1 310-328-0400 Fax. +1 310-328-2700 e-mail sic@suzumokikou.com

East Office : 375 North Street, Unit K, Teterboro, NJ 07608 U.S.A.
Tel. +1 201-568-1900 e-mail sic@suzumokikou.com

< Contact in Singapore >

Suzumo Singapore Corporation Pte. Ltd.

421 Tagore Industrial Avenue #04-11 Tagore 8, Singapore 787805
Tel. +65 6254-2080 Fax. +65 6254 2086 e-mail sales@suzumo-sg.com

雅麗盈設備有限公司

APEX NOBLE EQUIPMENT LTD

Tel: (852) 36901333, 36901338, Fax: (852) 36901339, Email: info.anel@gmail.com, info@anel.com.hk
Unit 5, 18/F., Wah Chun Industrial Centre, 95 Chai Wan Kok Street, Tsuen Wan, New Territories, Hong Kong.

香港荃灣柴灣角街95號華俊工業中心18樓05室
Website: www.anel.com.hk