

ENGLISH



Unique mechanism to produce soft fluffy rice

Can produce continuous or single maki rolls

Size selectable, in round or square shape

Adjustable cutting size with rotary cutter

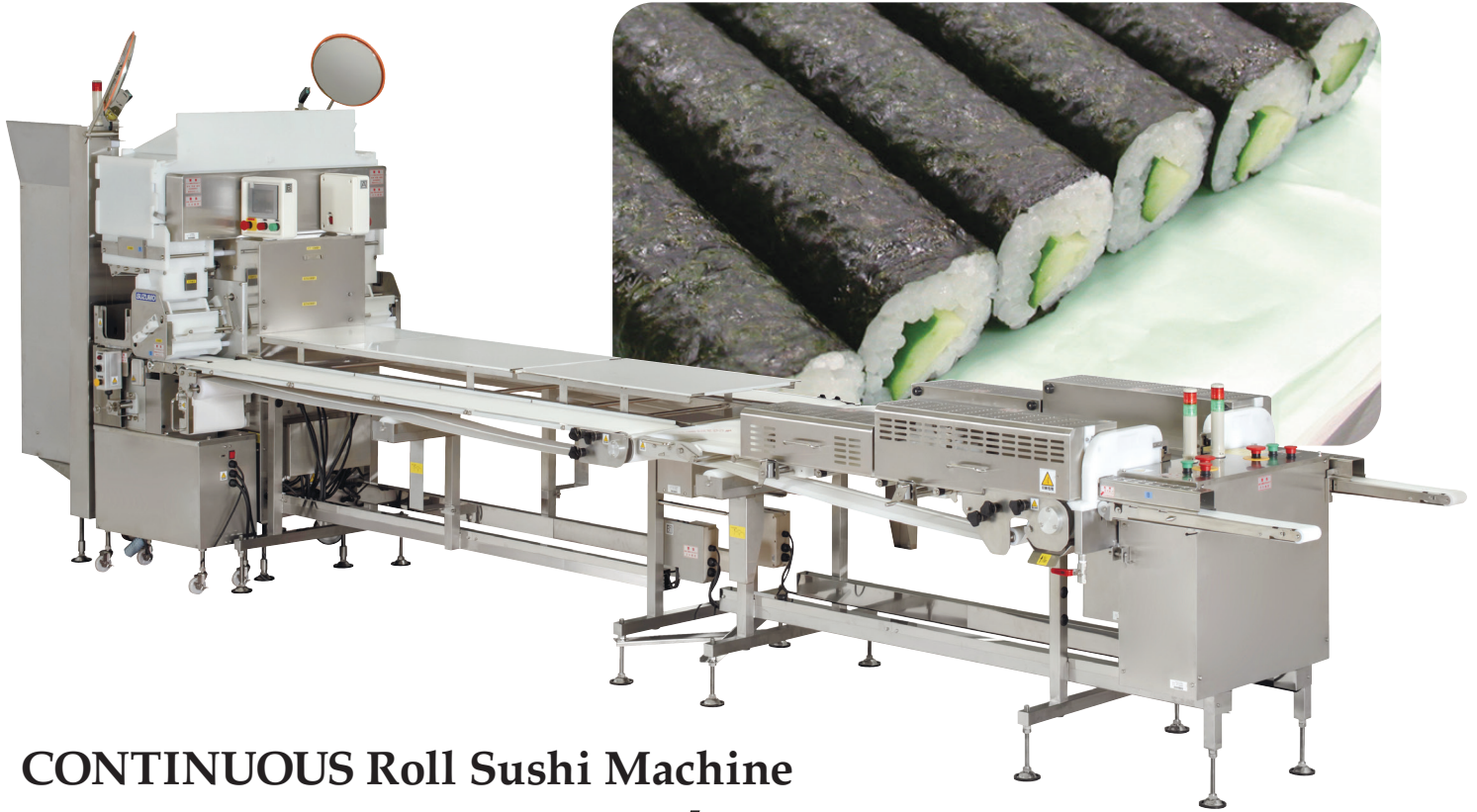

SVR-SAE-W

CONTINUOUS Roll Sushi Machine SVR-SAE-W/S

Produces 4000 rolls per hour continuously, as if they were hand made!!



Small



Medium



Large



Rice outside

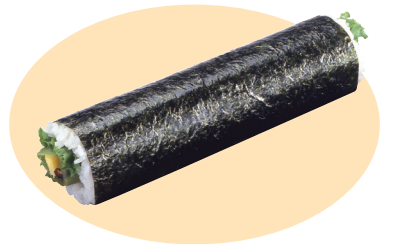

Single roll

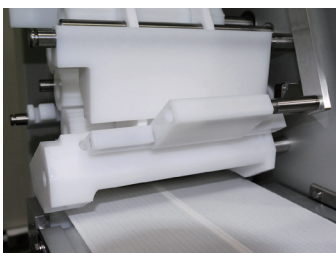

Rice spreading continuously. Rice sheet can be cut by required length.



Roll up from one side then the other side.

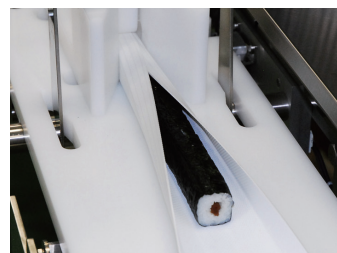

Rolls are formed gently.



Cut length is adjustable. The rotary cutter is always kept clean with alcohol.

Dimensions

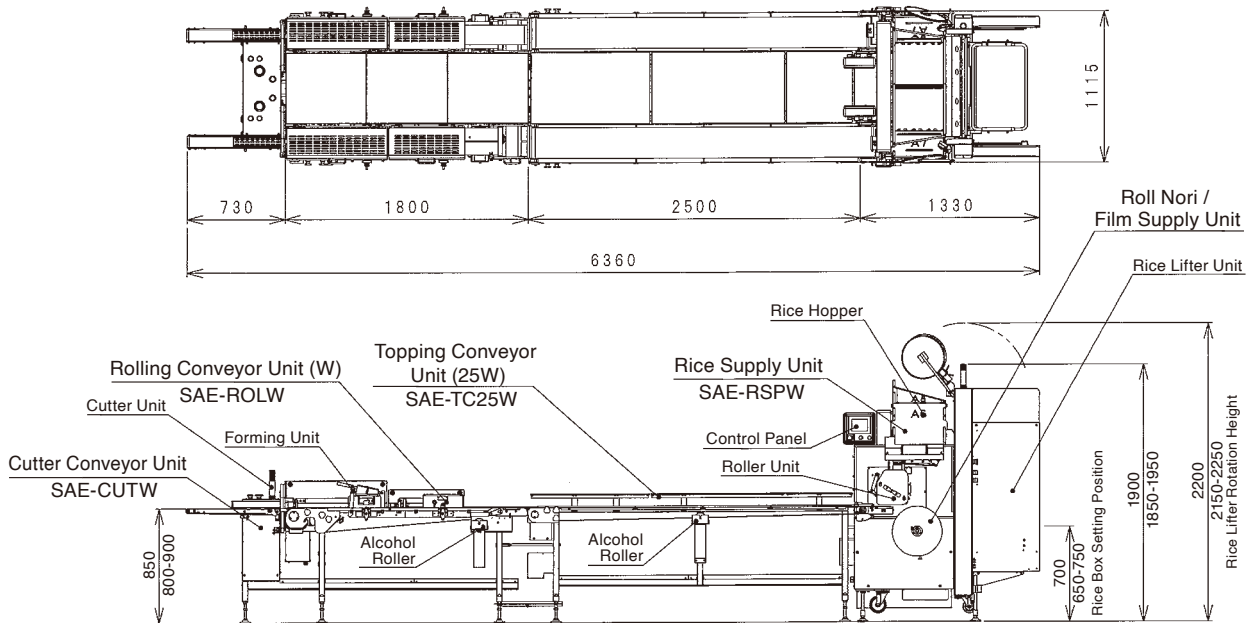

*The above drawing is made based on model SVR-SAE-W. (in mm)

Specifications

Model

SVR-SAE-W (double lines)
SVR-SAE-S (single line)

Power

3-phase, 200V 50/60Hz

Power consumption

1.7kW (excluding optional accessories)

Machine dimensions (in mm)

6360W x 1115D x 1900Hmm (Max. 2250Hmm)
Topping Conveyor Unit selectable (2/2.5/3/3.5m)

Capacity

4000 rolls per hour (SVR-SAE-W)

2000 rolls per hour (SVR-SAE-S)
(roll length at 180mm)

• Speed adjustable • Single roll selectable

Roll Size (selectable)

Small: 80×180mm (rice weight approx. 80g)
Medium: 120×180mm (rice weight approx. 140g)
Large: 155×180mm (rice weight approx. 235g)

Lifter Capacity

Under 20kgs

Hopper Capacity

15kg

Weight

Under 830kg (SVR-SAE-W)

Under 540kg (SVR-SAE-S)

Features

- Continuous output of soft, consistent rice sheet.
- Continuous rice sheet or single rice sheet selectable.
- Independent topping conveyor.
- Conveyor length is selectable. (2/2.5/3/3.5m)
- Unique forming mechanism, by rolling up from one side, then the other side.
- Roll size and shape can be changed by exchanging forming units.
- Rotary cutter will cut rolls sharply by variable lengths.
- Equipped with an interlock system for operator's safety.
- Each line has its own touch panel controller.
- Maximum capacity 4000 rolls per hour. (with 2 lines)
- Designed safe and clean.

* Designs and specifications subject to change without notice.

* Please follow the instruction in the operation manual when handling the machine.

* While capacity expresses the machine's performance capabilities, it is predicated upon the machine being operated correctly.

Suzumo Machinery Co., Ltd. Global Business Division

2-23-2, Toyotamakita, Nerima-ku, Tokyo 176-0012, Japan
Tel. +81 3-3993-1407 Fax. +81 3-3993-1756
e-mail overseas@suzumo.co.jp URL <http://www.suzumokikou.com>

< Contact in North America >

Suzumo International Corporation

Head Office : 1815 W. 205th Street, Suite 101 Torrance, CA 90501 U.S.A.
Tel. +1 310-328-0400 Fax. +1 310-328-2700 e-mail sic@suzumokikou.com

East Office : 375 North Street, Unit K, Teterboro, NJ 07608 U.S.A.
Tel. +1 201-568-1900 e-mail sic@suzumokikou.com

< Contact in Singapore >

Suzumo Singapore Corporation Pte. Ltd.

421 Tagore Industrial Avenue #04-11 Tagore 8, Singapore 787805
Tel. +65 6254-2080 Fax. +65 6254 2086 e-mail sales@suzumo-sg.com

雅麗盈設備有限公司 APEX NOBLE EQUIPMENT LTD

Tel: (852) 36901333, 36901338, Fax: (852) 36901339, Email: info.anel@gmail.com, info@anel.com.hk
Unit 5, 18/F., Wah Chun Industrial Centre, 95 Chai Wan Kok Street, Tsuen Wan, New Territories, Hong Kong.
香港荃灣柴灣角街95號華俊工業中心18樓05室
Website: www.anel.com.hk