

超小型壽司成形包裝機 SGP-SNB



POINT

- 生產能力 1000 ~ 2000 個 / 時調整
- 可以加裝辣根自動供給裝置
- 可以加裝日期打印機
- 壽司飯糰的重量可以調整
- 重量可以從 18 ~ 25g 之間



一次成形



二次成形



放魚片



包裝后排出

外形圖

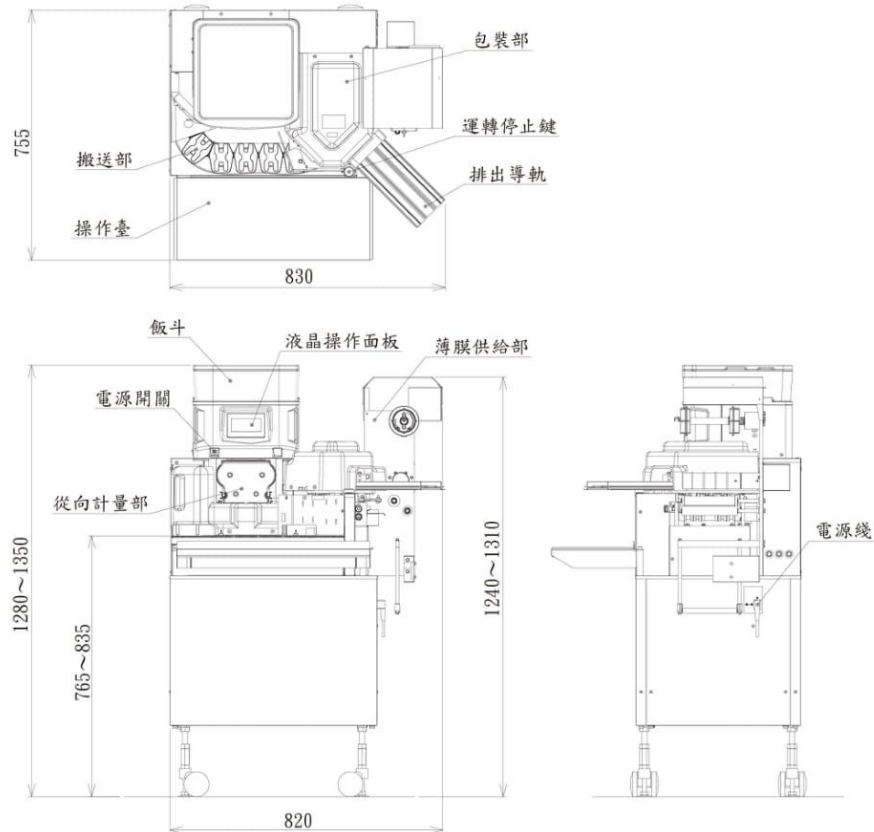

仕樣

型號	SGP-SNB
生產能力	1000, 1200, 1400, 1600, 1800, 2000 個 / 時 (可變)
尺寸	830W×755D×1280~1350Hmm (不安裝打印機)
電源	AC100~240V, 50/60Hz
消耗電力	330W
飯斗容量	10L(約6kg) *20g 壽司飯糰時可生產 300 個
飯糰重量	18, 20, 22, 25g (可變)
包裝尺寸	長 78× 寬 35× 高 30mm
薄膜要求	防霧型薄膜 寬 135 / 厚 芯寬 134mm 到 136mm
機器本體重量	約 144g

特點

- 本機器是日本鈴茂公司生產的第 5 代壽司成形包裝機。該機具有以下特點
- 1 壽司飯糰的口感不遜於日本專業壽司師傅。
 - 2 採用液晶操作面板，使用中文操作系統，和前款機型相比更加操作方便。
 - 3 大幅度降度了需要拆洗零件數量，減少每日拆洗時間。
(和前款設備相比減少了 20% 的零件)
 - 4 佔地面積小，狹小廚房內也可安裝。
 - 5 維護簡單，有中文故障內容提示

注意事項

機器的使用方法以『使用說明書』為準。
上述機器的生產能力為標準設計性能，實際操作時會有差異。
機器的外形以及性能等有可能在不預先通知的情況下進行改良。



海外營業部 (Overseas Business Division)

〒176-0012 東京都練馬区豊玉北2-23-2
Tel. +81 3-3993-1407 Fax. +81 3-3993-1756
e-mail overseas@suzumo.co.jp
URL http://www.suzumokikou.com



香港及澳門代理商
Agent of HK & Macau

ANEL

APEX NOBLE EQUIPMENT LTD.
雅麗盈設備有限公司

香港荃灣柴灣角街95號華俊工業中心18樓05號室

Flat 5, 18/F, Wah Chun Industrial Centre,
95 Chai Wan Kok Street, Tsuen Wan, New Territories, Hong Kong

Mobile: 852-94505051, 86-14715675669
Tel: 852-36901333, 36901338 Fax: 852-36901339
Website: www.anel.com.hk

Compact Sushi Forming / Wrapping Machine

SGP-SNB

This machine wraps each piece of sushi beautifully by film.

Wrapped sushi looks high quality, very clean and it actually keeps freshness by individual piece base which will excite customer's interest.



POINT

- The novel design which rice ball (Shari-dama) forming unit connected with film wrapping unit compactly.
- Keeps freshness to prevent the color changing of ingredient and drying sushi rice.
- Adoption of Easy-open film which is suitable wrapping sushi style for catering and take-out business.



Rice dividing and
1st forming



2nd forming
(wasabi for option)



Topping manually



Wrapped sushi comes
out automatically.

■Dimensions

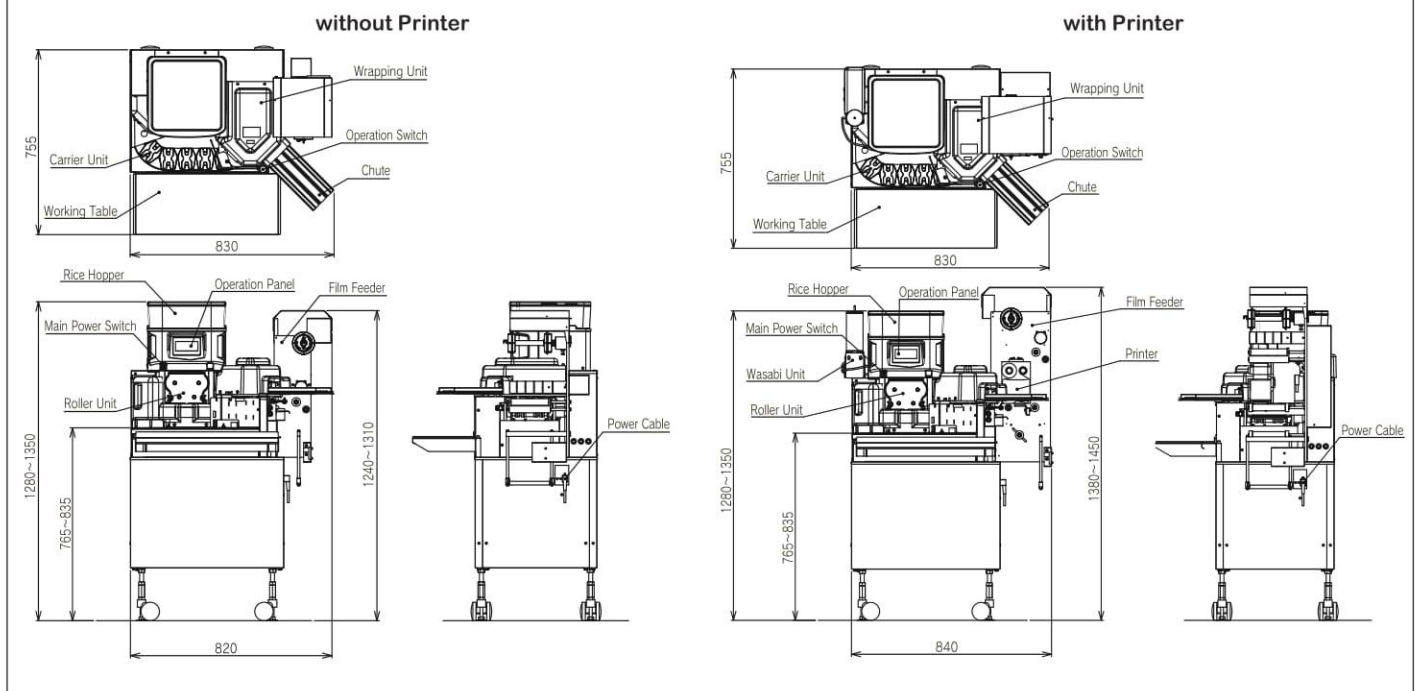

■Specification

Model	SGP-SNB-FT
Capacity	1000, 1200, 1400, 1600, 1800, 2000 pcs./hr. (selectable)
Machine Dimensions	830W×755D×1280-1350Hmm (without Printer) 840W×755D×1380-1450Hmm (with Printer) *Height becomes +5mm when the adjuster fixed
Power	Single-phase, AC100-240V, 50/60Hz
Power Consumption	350W (without Optional Items) 450W (with Optional Items)
Rice Hopper Capacity	Approx. 6.5kg of cooked rice
Rice Ball Size	18, 20, 22, 25g (Selectable)
Wrapping Dimensions	68L×35W×30Hmm
Wrapping Film Specification	135mm width, 30μ thickness
Machine Weight	144kg (without Optional items)
Optional Items	Printing Unit, Wasabi Unit, Printer, Sub Hopper

* Capacity expresses the machine's performance capability.
The actual result may vary depending on the operator.

■Features

- 2 in 1 design
(Sushi Forming & Wrapping).
- Fluffy perfect rice ball are made by Suzumo innovative technology.
- User Friendly LCD touch panel.
- Easy to assemble/disassemble food contacting parts for cleaning.
- Just pull both sides of film to enjoy the Sushi (Patented).



*Designs and specifications subject to change without notice.

Suzumo Machinery Co., Ltd. Global Business Division
2-23-2, Toyotamakita, Nerima-ku, Tokyo 176-0012, Japan
Tel. +81 3-3993-1407 Fax. +81 3-3993-1756
e-mail overseas@suzumo.co.jp URL <http://www.suzumokikou.com>

< Contact in North America >

Suzumo International Corporation

Head Office : 1815 W. 205th Street, Suite 101 Torrance, CA 90501 U.S.A.
Tel. +1 310-328-0400 Fax. +1 310-328-2700 e-mail sic@suzumokikou.com
East Office : 375 North Street, Unit K, Teterboro, NJ 07608 U.S.A.
Tel. +1 201-568-1900 e-mail sic@suzumokikou.com

< Contact in Singapore >

Suzumo Singapore Corporation Pte. Ltd.

421 Tagore Industrial Avenue #04-11 Tagore 8, Singapore 787805
Tel. +65 6254-2080 Fax. +65 6254 2086 e-mail sales@suzumo-sg.com

香港及澳門代理商
Agent of HK & Macau

ANEL

APEX NOBLE EQUIPMENT LTD.

雅麗盈設備有限公司

香港荃灣柴灣角街95號華俊工業中心18樓05號室

Flat 5, 18/F, Wah Chun Industrial Centre,

95 Chai Wan Kok Street, Tsuen Wan, New Territories, Hong Kong

Mobile: 852-94505051, 86-14715675669

Tel: 852-36901333, 36901338, Fax: 852-36901339

Website: www.anel.com.hk